



CS700 - COMPACT SERIES

GRAVITY SHAKE FREEZER

This counter-model shake freezer features a small footprint. Great for restaurants, QSR's, ice cream shops, self-serve college and university cafeterias, retirement villages and healthcare facilities.

Exclusive Auger Design - gently blends, reducing agitation & maintaining product quality & consistency

Consistency Control - Designed to dispense the finest frozen product available

Air Filter - washable filter keeps the condenser clean

Compact Design - with a small footprint

Experience Tells - Electro Freeze has been manufacturing quality frozen treat machines since 1929. Superior engineering, product innovations, sturdy construction, quality craftsmanship and dependable performance are Electro Freeze hallmarks

Superior Service Support - backed by a world-wide distributor network

OPTIONAL

Front Mount Shake Mixer (as shown)

Flavor Rack

Splash Guard (as shown)

Top Air Discharge Chute - the top air discharge chute on air cooled models allows units to be set side by side and air flow to be diverted up.

Cabinet - an optional commercial grade stainless steel cabinet is available includes heavy duty casters, a sturdy latch and give you 6 cubic feet of storage.



CANADA'S LEADING DISTRIBUTOR OF FOOD STORE & BEVERAGE EQUIPMENT SINCE 1946.

1.888.443.1946

1232 - 36 Avenue NE, Calgary, AB T2E 6M8 | info@wr.ca | www.wr.ca

TECHNICAL DATA

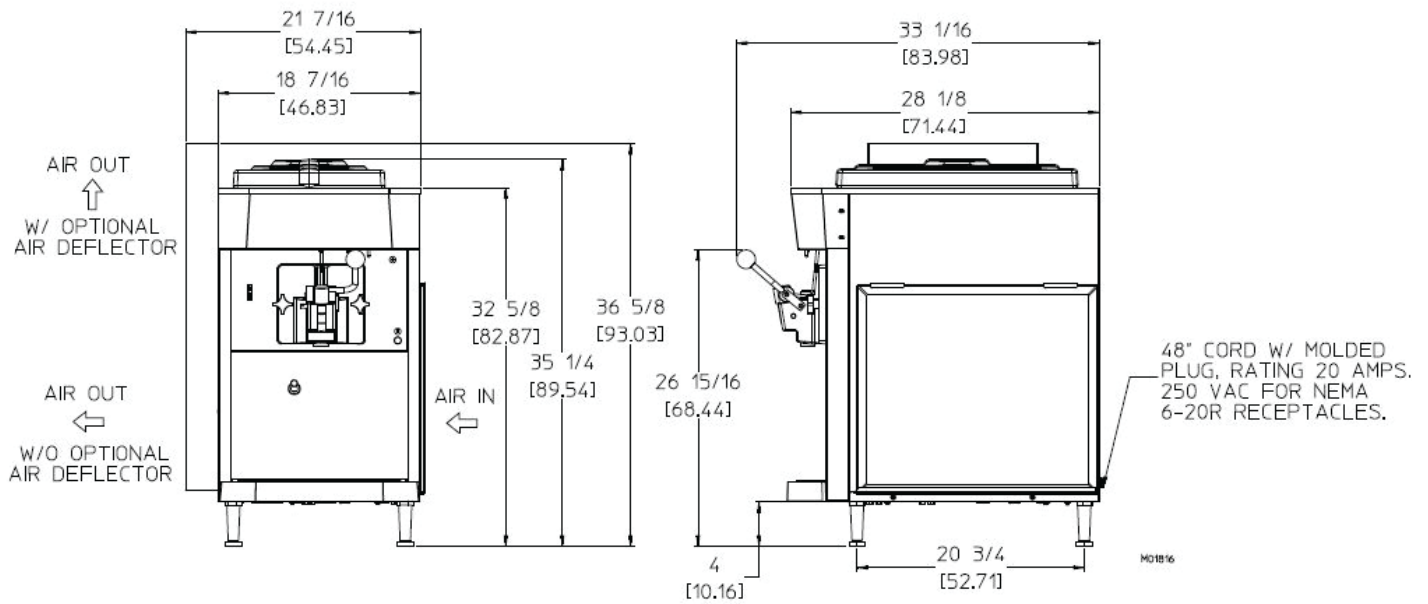

TECHNICAL SPECIFICATIONS

WEIGHT	lbs	kg
Net	294	134
Crated	390	177
Volume	39.5 cu.ft.	1.2 cu.m.
DIMENSIONS	in	cm
Width	18-7/16	46.83
Depth	28-1/8	71.44
Height	35-1/4	89.56
ELECTRICAL	Total Amps	NEMA Plug Type
208-230/60/1 Air	12.5	6-20P

ELECTRICAL:

One dedicated electrical connection is required. Connects to a standard NEMA 6-20R receptacle. See electrical chart for the proper requirement. Consult your local electrical codes for cord and receptacle specifications

BEATER MOTOR:

One, 1.5 hp

REFRIGERATION SYSTEM:

One, 8,000 Btuh. R404a. Btuh may vary depending on compressor used.

AIR COOLED:

3" (7.6cm) air space required on both sides and rear panel for proper air circulation.

MIX HOPPER CAPACITY:

One - 20 quarts (18.8 L)

FREEZING CYLINDER CAPACITY:

One - 7.6 quarts (7.1 L)



Due to continual product improvements all specifications are subject to change without notice.

WESTERN REFRIGERATION & BEVERAGE EQUIPMENT LTD.

1-888-443-1946 | 1232 - 36 Avenue NE, Calgary, AB T2E 6M8 | info@wr.ca | www.wr.ca